



Business Solutions Company

A person in a white shirt is holding a stack of papers. The background is bright and slightly blurred, suggesting an office or professional setting. A large orange circle is overlaid on the image, containing the text 'WE CREATE SUCCESS WITH CONFIDENCE' in white, bold, uppercase letters. The text is arranged in three lines: 'WE CREATE', 'SUCCESS WITH', and 'CONFIDENCE'.

**WE CREATE
SUCCESS WITH
CONFIDENCE**

INTRODUCTION

DIRECT SOLUTIONS Is A Leading General Contractor Company, Suppling, Designing, Installing Total Solution Systems For Both Professional And High-end Consumer Markets. Over The Years, DIRECT SOLUTION Company Has Gained a Reputation Thanks To Its Strong Commitment On Innovation And Great Passion For Outstanding Service Quality.

Indeed, DIRECT SOLUTION Company Invests Over 20% Of Its Human Resources And Over 10% Of Total Turnover In Consultation Activities, Assuring Constant Innovation Of Its Products.

General Manager

PHILOSOPHY

We push the limits of technology to create outstanding solutions to our customers. With the highest of ethical standards and pure dedication to excellence in all solution delivery and implementation aspects, we aspire to exceed our customers' expectations.

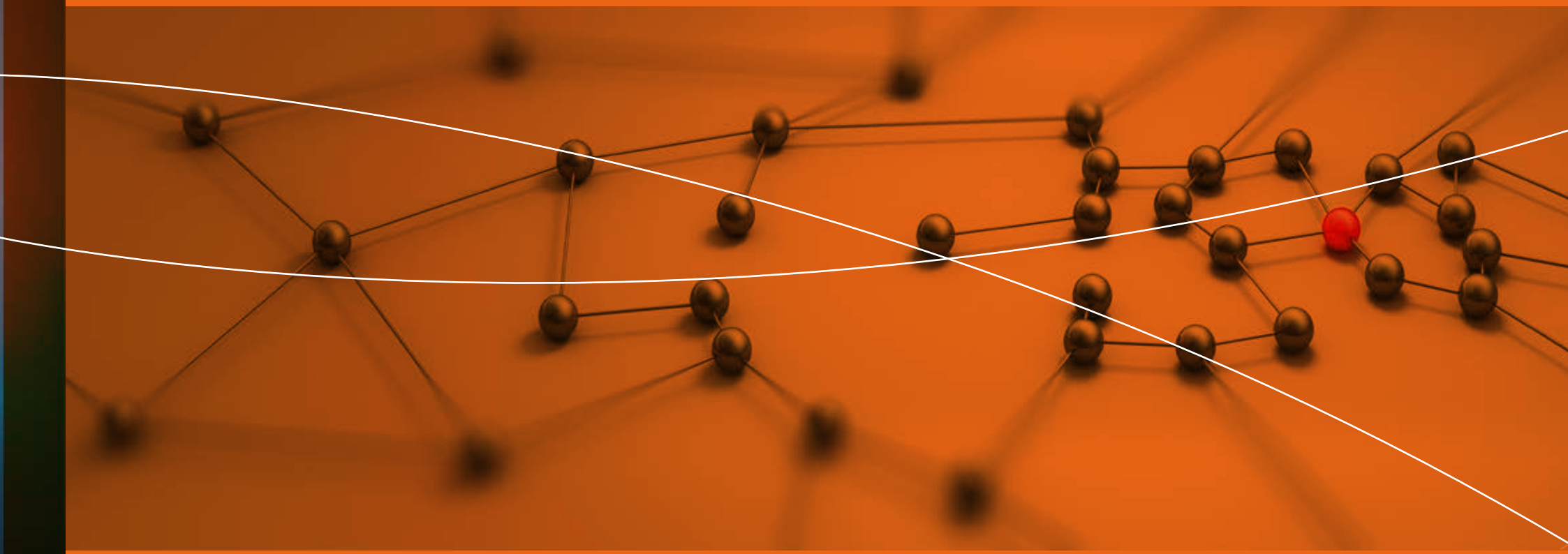



OVERVIEW

Direct solutions is a network and security solution emerging company based in KSA. we specializes in providing comprehensive network and security solutions from large-scale to medium-scale businesses. we aim to deliver top-notch services that ensure the integrity, availability, and confidentiality of your network infrastructure. Our approach combines expert consultation, robust network design, trending security measures, end-to end network solutions and ongoing support to create a secure and reliable IT environment for your organization.



**NETWORK
SOLUTION**



Fiber connectivity

Fiber Optic Cables single mode and multimode

designed to provide high-speed, reliable, and secure data transmission for various applications.

Connectors and Patch Cords fiber optic connectors and patch cords compatible with different cable types.

Cable Management Solutions: racks, enclosures, trays, and organizers to help customers efficiently organize and protect their fiber optic cables.

Testing and Measurement Equipment

installation, maintenance, and troubleshooting of fiber optic networks. Our skilled technicians ensure the highest quality standards and quick turnaround times.

UTP connectivity:

UTP cables

available in various categories, including CAT5e, CAT6, CAT6a, and CAT7, to meet the specific requirements of different applications.

Patch Cords and Connectors

We provide high-quality UTP patch cords and connectors that ensure seamless connectivity and efficient data transfer

Testing and Certification

We provide testing and certification services to ensure the performance and compliance of UTP cable installations.

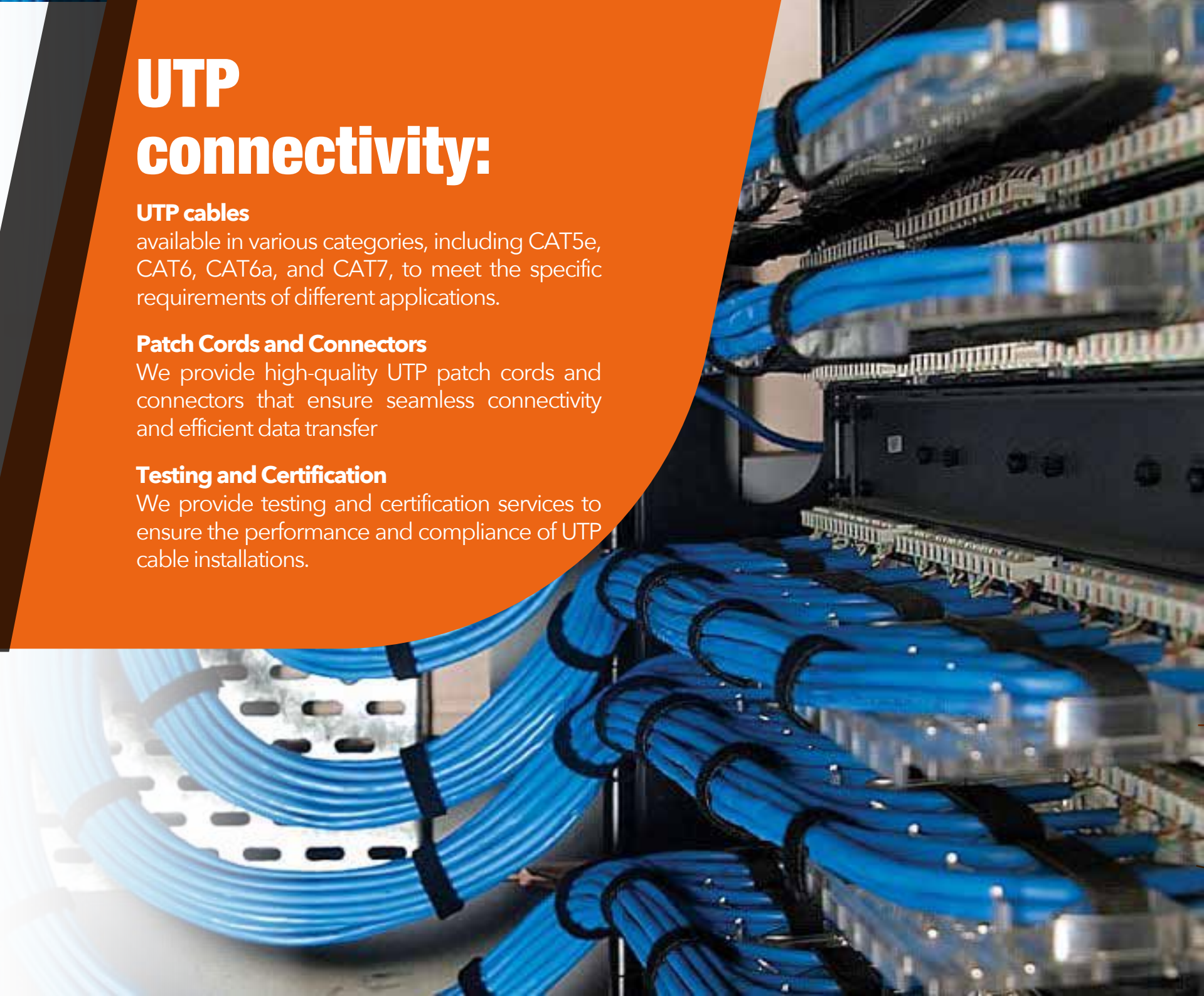

Network and wireless solutions:

Routing and switching

routers designed to deliver secure and efficient connectivity

Enterprise Routers

provide scalable and flexible connectivity, advanced security features, and robust performance, empowering organizations to build efficient and reliable networks.

Small Business Routers

cost-effective, ease setup and feature-rich routers tailored for small businesses and home offices.

Switches

suitable for different network sizes and requirements. We offer managed switches, unmanaged switches, and PoE switches that provide reliable and high-speed data transfer.

Network Management and Monitoring

network management software and tools to facilitate efficient configuration, monitoring, and troubleshooting of routers and switches.



Wireless solutions:

Wireless Network Design and Deployment

Our team of experienced network engineers analyzes business requirements, conducts site surveys, and designs scalable and robust wireless networks that provide high-speed connectivity and seamless coverage.

Wireless Network Infrastructure

access points, controllers, switches, and network management systems which they are designed to deliver reliable, high-performance, secure wireless connectivity.

Wireless Network Monitoring and Management

monitoring of network health, performance metrics, and security events and centralized management platforms that simplify network administration, troubleshooting, and configuration.

Wireless Site Surveys and RF Planning

We conduct wireless site surveys and radio frequency (RF) planning to assess and optimize wireless network coverage and performance. Our experts utilize specialized tools and techniques to analyze signal strength, interference, and channel allocation, ensuring optimal signal quality and coverage for wireless networks.

UPS

What is a UPS?

Put simply, a UPS is a device that:

1. Provides backup power when utility power fails, either long enough for critical equipment to shut down gracefully so that no data is lost, or long enough to keep required loads operational until a generator comes online.
2. Conditions incoming power so that all-too-common sags and surges don't damage sensitive electronic gear.

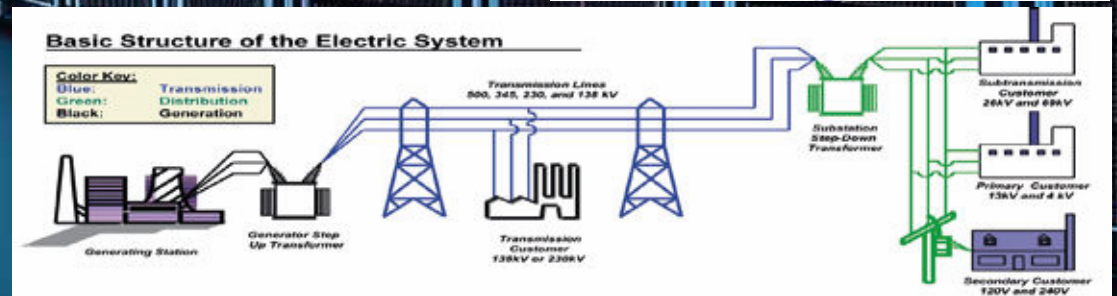



Network, Data and application security:

Firewalls

NGFW to secure networks against unauthorized access, malware, and other cyber threats. Our firewall appliances offer advanced threat detection, intrusion prevention, and granular access control features. It includes built-in IDPS, VPN, web VPN and proxy solutions.

Security Information and Event Management (SIEM)

centralized monitoring, correlation, and analysis of security events across the network. They enable proactive detection and response to security incidents, improving threat visibility and incident management.

Network Access Control (NAC): control access to network resources, ensure secure authentication, device compliance checks, and automated network segmentation to mitigate risks and prevent unauthorized access.

Endpoint Protection Platforms (EPP)

secure endpoints, including desktops, laptops, servers, and mobile devices, provide real-time threat detection, malware prevention, data encryption, and centralized management capabilities.

Antivirus and Anti-Malware Solutions: protect endpoints against known and emerging threats, advanced scanning techniques, behavior-based detection, and machine learning algorithms to identify and eliminate malicious software.

Application Firewall

protect web and mobile applications from attacks such as SQL injection, cross-site scripting (XSS), and cross-site request forgery (CSRF). Our application firewalls provide real-time threat detection, traffic filtering, and granular access control to ensure application security.

Secure Web Gateways

protection against web-based threats, including malware, phishing attacks, and malicious websites. They offer URL filtering, content inspection, and malware scanning to ensure safe and secure web browsing.

Email Security

protect against spam, phishing attempts, malware attachments, and email-based threats. Our solutions employ advanced filtering, threat intelligence, and encryption to safeguard email communications.

Vulnerability Management: identify, prioritize, and remediate security vulnerabilities across your organization's infrastructure. Our experts help you establish effective patch management processes and implement proactive vulnerability scanning.

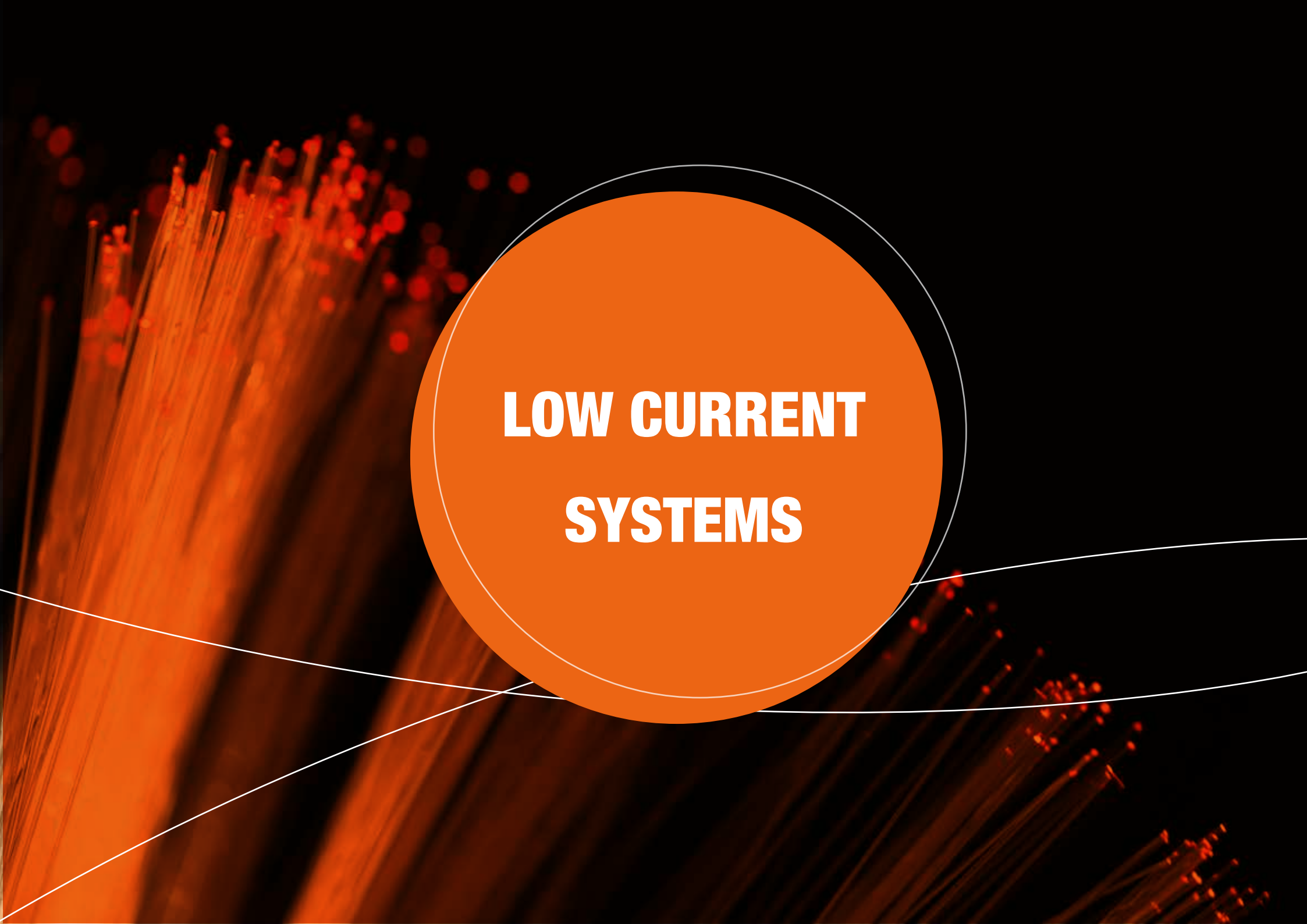

The image features a dark background with several bundles of fiber optic cables. The cables are illuminated from behind, creating a warm orange glow. The ends of the cables are visible as small, bright orange dots. In the center of the image, there is a large, solid orange circle. Inside this circle, the text "LOW CURRENT SYSTEMS" is written in a bold, white, sans-serif font. The text is arranged in two lines: "LOW CURRENT" on the top line and "SYSTEMS" on the bottom line. The overall composition is clean and modern, emphasizing the technology of fiber optics.

**LOW CURRENT
SYSTEMS**

BMS System

- Comfortable & safe Enough for your building by controlling ...

- Air Handling Units.
- Fan Coil Units.
- Chillers.
- Pumps.
- Boilers.
- VFD's.

- safe and comfortable working environment.

- energy saving & efficient operation at reduced time & cost.

- Centralized WorkStation Computer

- DDC Controllers.

- Micro-processor based.

- Fully programmable.

- Controls the HVAC equipment of the building.

- Field devices

- Temperature, Humidity, Pressure sensors.

- Valves, Actuators.

- Centralized WorkStation Computer

- With powerful user-friendly software.

- Used for everyday building operation.

- DDC Controllers

- Micro-processor based.

- Fully programmable.

- Controls the HVAC equipment of the building.

- Field devices

- Temperature, Humidity, Pressure sensors.

- Valves, Actuators.

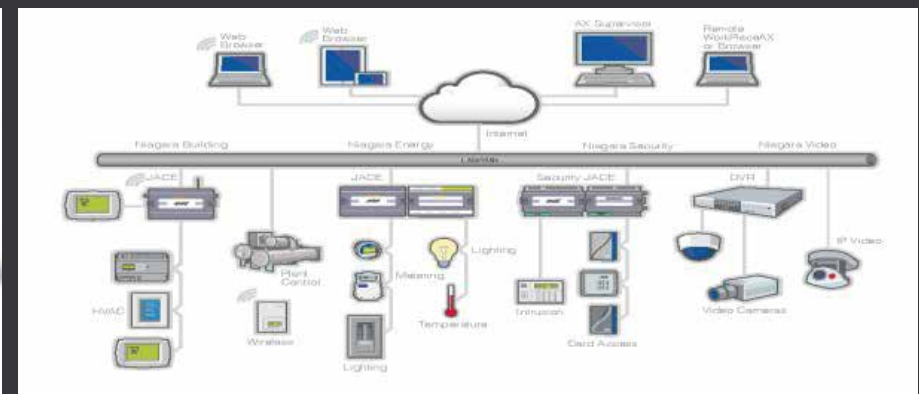

Security & Surveillance

CCTV & ACS System

- Access Control.
- PTZ Camera.
- Optical Cameras.
- Face Recognition Cameras Enforcement cameras
- Gates Cameras.
- Automatic gates RFID.
- Command Control Center.
- Face Recognition Cameras Enforcement cameras
- Gates Cameras.
- Automatic gates RFID.
- Command Control Center.

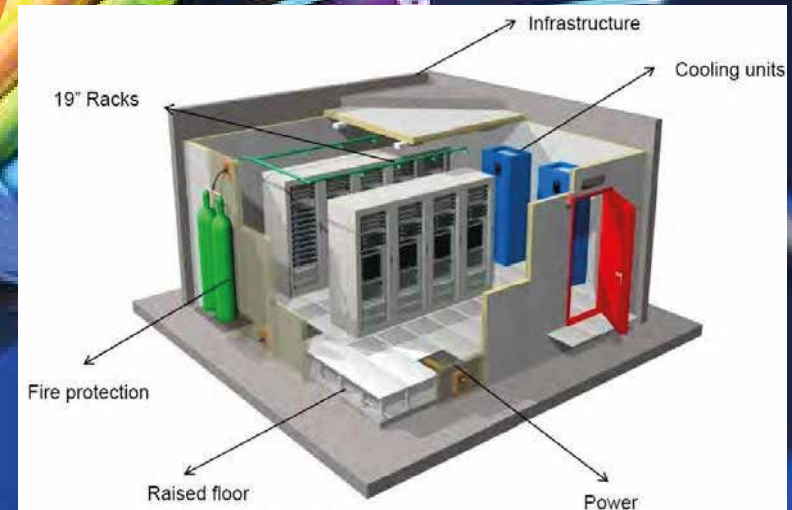

Fire Alarm System.

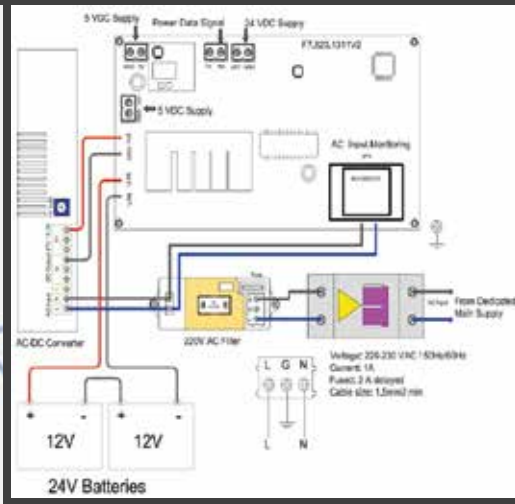

Master Clock System

Analog Clock system

Digital Clock system

Master Clock

Time Zone clock

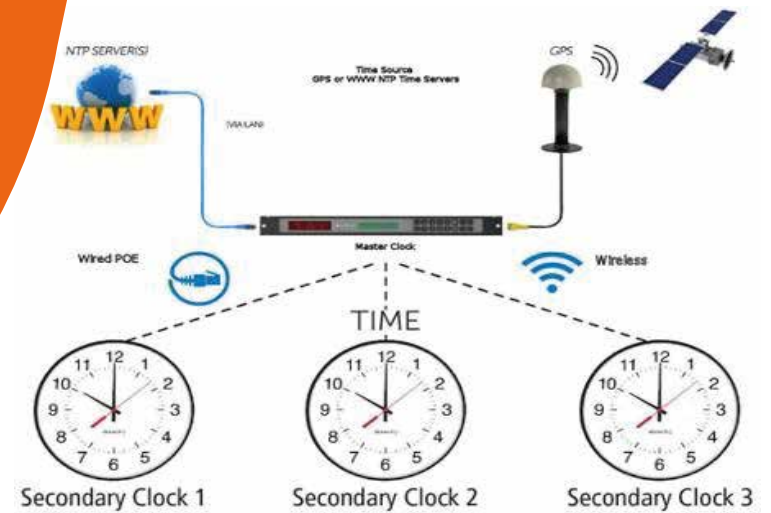

Public Address and Audio/ Visual System

- Conference Microphone System.
- Amplifiers.
- Wireless Microphone System.
- Speakers.
- Bell Timer.
- Infrared wireless Microphone.
- Digital Signage.
- Interactive System.

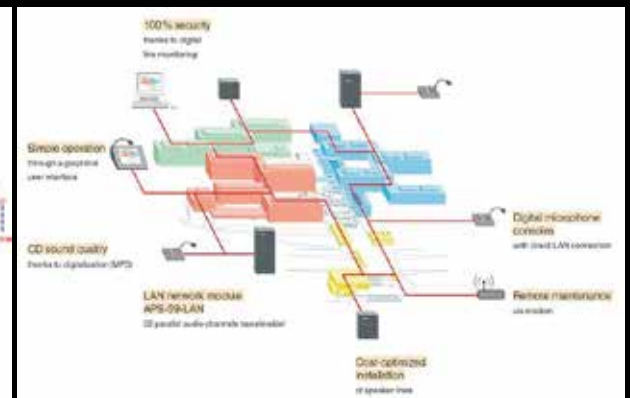
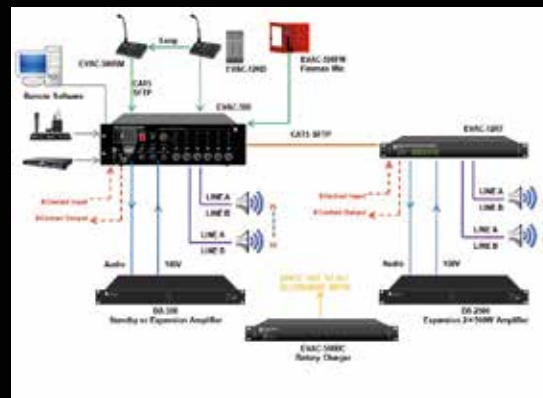
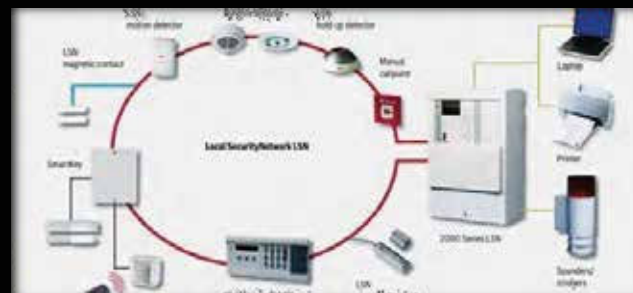

MATV / IPTV System

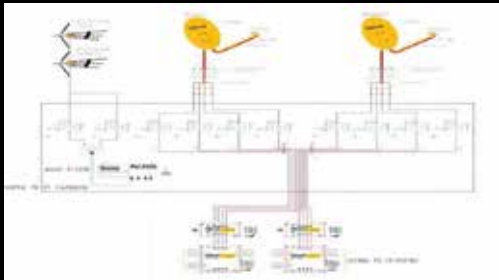
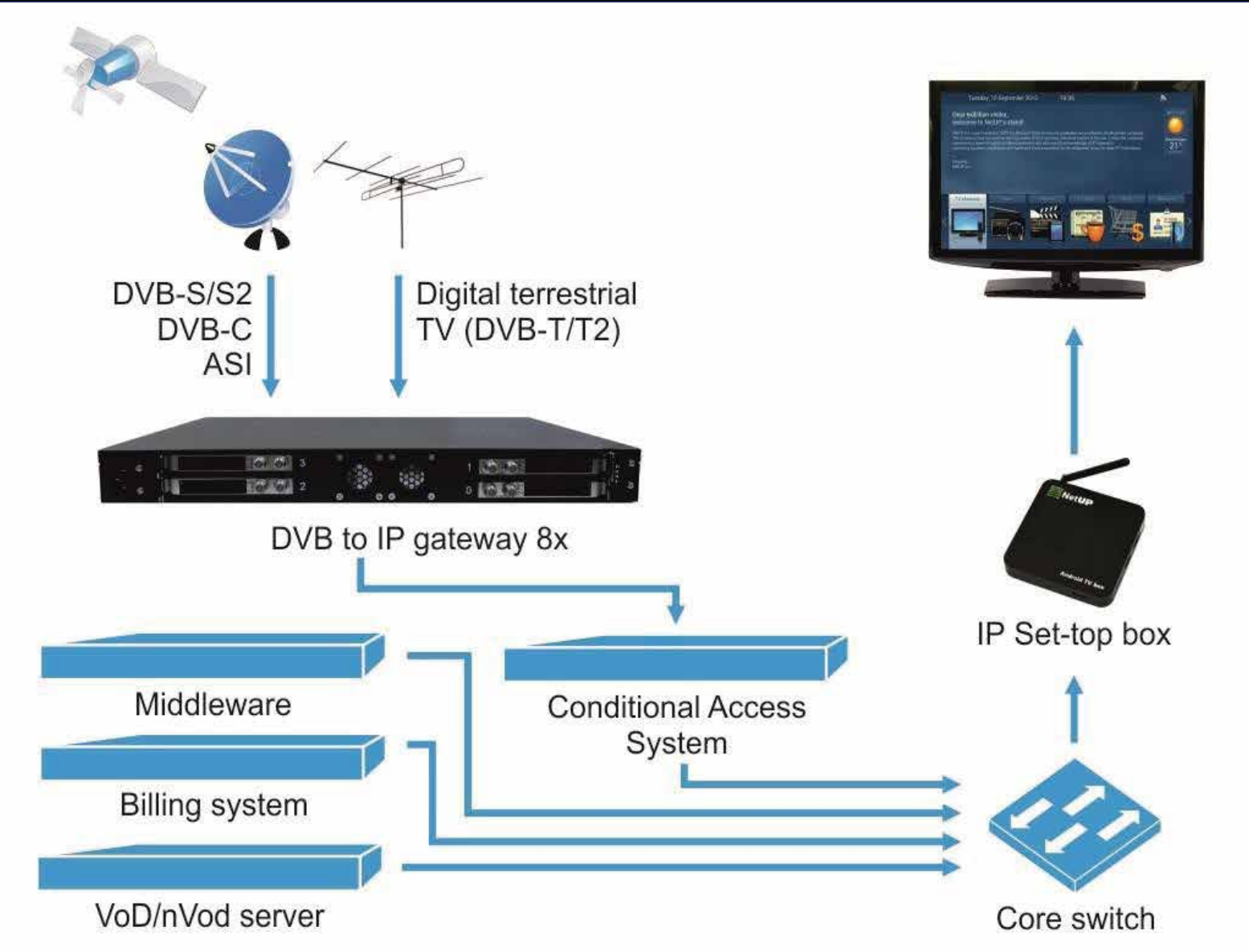

Guest Room Management System

Continuum Panel and Control Panel

Touch Control Thermostat

Smart Switch Wing Device

Smart Touch Control Panel

Smart Touch Control Panel

Honeywell INNCOM Elements

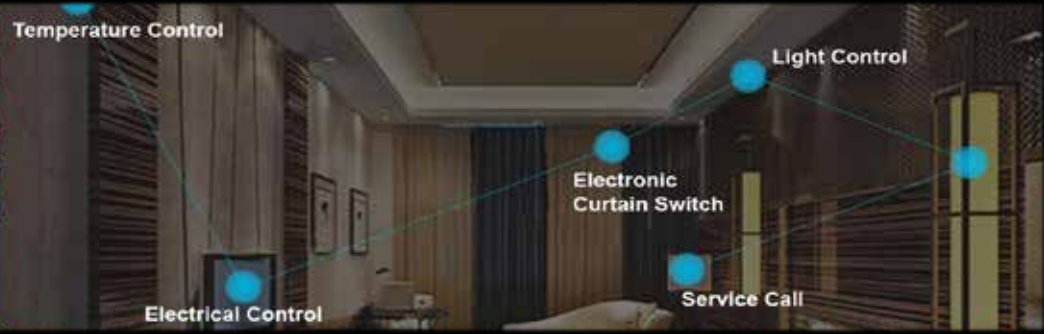

CCTV Camera Setup

In-Door & Outdoor Expert team

Expert designing and technical team for an end to end BOQ & helping you choose the right OEM which will fulfill your requirement appropriately.

Direct solution is a distributor of many CCTV brands and can supply, install & maintenance services of wide range of IP security Cameras namely Analog & Digital.

DVR, NVR Video transmission equipment and workstations Direct Solutions has the capability of linking

Integrating various video surveillance systems like Milestone, Lensec, Axis, Lenel etc.

The Key differentiators from all other System integrators is our desire to first keenly study the need on Why you need surveillance equipment's in the first place. Whether you are facing any theft issue or looking out for checking your employee efficiency or internal SOP adherence, your customer experience, or mere Government compliance.



DOOR ACCESS CONTROL SYSTEM

Access control is more than just securing physical entrances; it's about controlling who has access to your premises, assets, and sensitive information.

Whether you're a business and enterprise owner or a homeowner seeking to protect your family, employees, and assets, access control companies offer tailored solutions that align with your specific needs and preferences. Comprehensive physical access control systems for organizations of all sizes

Proven, Trusted and Open Access Control

The OnGuard® physical access control system exemplifies our commitment to providing a superior, integrated and customizable security management system that meets your evolving needs. The OnGuard system delivers solutions that seamlessly unify access control and video monitoring for a wide range of industries





Our Partner



Our Partner



Our Client



مستشفى وادي الدواسر

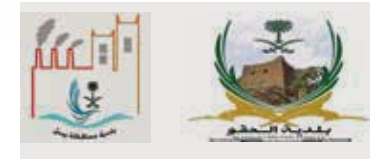



**thank you our
valued partener**



www.directsolutions-it.com
info@directsolutions-it.com
Kingdom Of Saudi Arabia,
Riyadh -Al-Takhassusi St.
P.O. Box 86493 - Riyadh 11622
Tel.:00966 11 4643035